



The Clear Choice
Water Filtration Systems

www.aquafilter.com

HB1C & HB2C series

**Big Blue® filter housings
for cold water**

General Description:

AQUAFILTER FH10Bx-WB and FH20Bx-WB - 10" and 20" **Big Blue®** - type filter housings offer the versatility to meet all customer large-capacity filtration needs.

FH10Bx-WB and FH20Bx-WB are dedicated for high flow cold water on commercial and industrial applications.

FH10Bx-WB and FH20Bx-WB housings are compatible with a broad range of 4 1/2" x10" and 4 1/2" 20" type cartridges widely available on the market.

This housing can be used in a commercial setting due to its high efficiency.

Filter housing consists of housing sump and filter head with 1", 1 1/4" and 1 1/2" inlet/outlet inserts. Heads are equipped with a pressure relief valve (providing ability to release air pressure collected during cartridge replacement procedure). Set include: 10" or 20" BB type filter housing, wrench and mounting bracket.

This filter housing can be equipped with one or two pressure gauges (purchased separately).



Made in EU



Features:

- High quality
- NSF certified
- WRAS certificate
- FDA CFR Title 21 Compliance
- Competitive Pricing
- Factory Tested
- Domestic and commercial use
- Large capacity housing suitable for high flow applications
- Pressure relief/bleed on inlet side of cap
- Ideal for POE use
- Maintenance Free -Saves \$, Time and Labor
- Easy to connect to cold water inlet
- Easy to install, No Electricity, No Drain Required
- Full flow 1", 1/4", 1 1/2" ports
- Made in EU with High Performance Components

- FH10B1-WB** - 1"
- FH10B54-WB** - 1 1/4"
- FH10B64-WB** - 1 1/2"

- Set include:**
- 10" filtr housing Big Blue® type
 - wrench
 - mounting bracket with screws
 - instruction
 - color box
 - antibacterial and antimicrobial filter centralizing ring

- FH20B1-WB** - 1"
- FH20B54-WB** - 1 1/4"
- FH20B64-WB** - 1 1/2"

- Set include:**
- 20" filtr housing Big Blue® type
 - wrench
 - mounting bracket with screws
 - instruction
 - color box
 - antibacterial and antimicrobial filter centralizing ring

Applications:

- Domestic installations
- Pre-filtration systems
- Food industry
- Industry laboratories

To **FH20Bx_Land FH10Bx_M** series housing an antibacterial centering ring is added.
TOTALLY FREE OF CHARGE!



This Cartridge is Tested and Certified by NSF International against NSF/ANSI Standard 42 for materials requirements only.

COMPONENT





The Clear Choice
Water Filtration Systems

www.aquafilter.com

HB1C & HB2C series

Big Blue® filter housings
for cold water

Additional accessories



FXBRPBB-B
Mounting bracket



FXBRBB
Single white metal
mounting bracket for
Big Blue® housings



FXBRBB2
Double white metal
mounting bracket for
Big Blue® housings



FXBRBB3
Triple white metal
mounting bracket for
Big Blue® housings



FXWR1BB-BL
Wrench



KCGA-1
Pressure
gauge



KCGA-1-E2
Pressure gauge
extension



OR-N-1524X57
NBR O-ring for the
housings HB1B,
HD1D, HD1C, HB2B,
HD2D, HD2C series



NI-412-CENT_AB
Antibacterial and Antimicrobial
Filter cartridge centralizing ring

Specifications:

Housing: polypropylene
Cap: polypropylene
Pressure relief valve: brass
O-ring: NBR
Thread: 1", 1 1/4", 1 1/2" BSP
Operating Pressure: 6 bar (90 psi)
Minimum working temperature: 2°C (35°F)
Maximum working temperature: 45°C (113.00°F)*

Dimensions (H x OD) FH10Bx-WB: 345 mm x 175 mm
Dimensions (H x OD) FH20Bx-WB: 605 mm x 175 mm

Cartridge dimensions FH10Bx-WB: 9 7/8" x 4 1/2" (250 mm x 115 mm)
Cartridge dimensions FH20Bx-WB: 20" x 4 1/2" (508 mm x 115 mm)

* Tested and certified by WRAS for 23°C only.

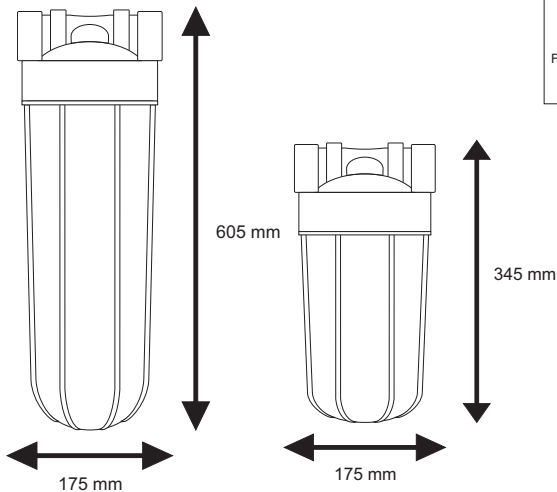
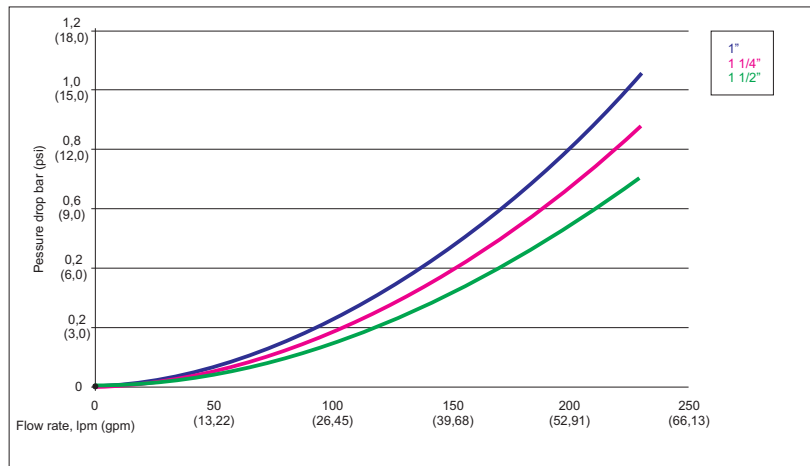

NOTE

We strongly recommend regularly scheduled maintenance and replacement of the filter cartridge in order for the product to perform properly. Replace the filter cartridge at least every 3 or 6 months (depending on water quality).

LIMITED WARRANTY: AQUAFILTER warrants that this product is free from defects in materials and workmanship.

This warranty, together with any and all warranties implied by law, shall be limited to a period of two (2) years from the date of original purchase. This limited warranty does not apply to failures that result from abuse, misuse, alteration or failure to properly comply with installation or cartridge change instructions.

All Aquafilter images, trademarks, logos, and other intellectual property are the sole and exclusive property of Aquafilter, Inc. and may not be used without our express written permission.

**Aquafilter
Manufacturing
Facility**



Aquafilter Inc.
Hunt Valley 21030, USA
us@aquafilter.com



Aquafilter Germany
15234 Frankfurt, Germany
de@aquafilter.com



Aquafilter Europe
91-222 Lodz, Poland
pl@aquafilter.com

